



22136203



**DESIGN TECHNOLOGY
HIGHER LEVEL
PAPER 3**

Friday 17 May 2013 (morning)

1 hour 15 minutes

Candidate session number

0	0								
---	---	--	--	--	--	--	--	--	--

Examination code

2	2	1	3	-	6	2	0	3
---	---	---	---	---	---	---	---	---

INSTRUCTIONS TO CANDIDATES

- Write your session number in the boxes above.
- Do not open this examination paper until instructed to do so.
- Answer all of the questions from one of the Options.
- Write your answers in the boxes provided.
- A calculator is required for this paper.
- The maximum mark for this examination paper is *[40 marks]*.



0140

Option A — Food science and technology

A1. Figure A1 shows a range of craft-produced breads.

Figure A1: Craft-produced breads



[Source: http://commons.wikimedia.org/wiki/File:Various_grains.jpg]

(a) State **one** reason why craft-produced breads are generally more expensive than mass-produced breads. [1]

.....

.....

(b) Outline how gluten in flour contributes to the final texture of dough. [2]

.....

.....

.....

.....

(This question continues on the following page)



(Question A1 continued)

- (c) Explain how the addition of yeast to bread dough contributes to the physical properties of bread. [3]

.....

.....

.....

.....

.....

.....



A2. (a) State **one** advantage of the FlavrSavr™ tomato over traditionally grown tomatoes. [1]

.....
.....

(b) Outline **one** reason why the FlavrSavr™ tomato was withdrawn from the market. [2]

.....
.....
.....
.....



A3. Figure A2 shows “The eatwell plate” which has been developed by the Food Standards Agency a statutory agency in the United Kingdom.

Figure A2: The eatwell plate



[Source: © Crown copyright. Public Health England in association with the Welsh Government, the Scottish Government and the Food Standards Agency in Northern Ireland.]

(a) Outline **one** reason why it is important that governments raise public awareness of food-related health issues. [2]

.....

.....

.....

.....

(b) Identify **one** reason why “The eatwell plate” system would not be appropriate for children below the age of two years. [2]

.....

.....

.....

.....



A4. Explain how travel and the media have promoted the development of an international cuisine. [6]

.....

.....

.....

.....

.....

.....

.....

.....

.....

.....

.....

.....

.....

.....

.....



0640

A5. (a) Describe **one** measure used to estimate the number of hungry people in a country. [2]

.....
.....
.....
.....

(b) List **two** criteria for food security. [2]

.....
.....
.....
.....

(c) Outline **one** reason why international strategies for maintaining food security are important. [2]

.....
.....
.....
.....



A6. (a) Explain **one** way in which proper cooking of food can help control food poisoning. [3]

.....

.....

.....

.....

.....

.....

(b) Explain **one** way in which good personal hygiene can help to prevent food poisoning. [3]

.....

.....

.....

.....

.....

.....



Option B — Electronic product design

B1. **Figure B1** shows a circuit designed to operate a relay. The circuit could be used to activate an alarm system and could be incorporated into a home security system. The switch is initially closed.

Figure B1: A circuit designed to operate a relay

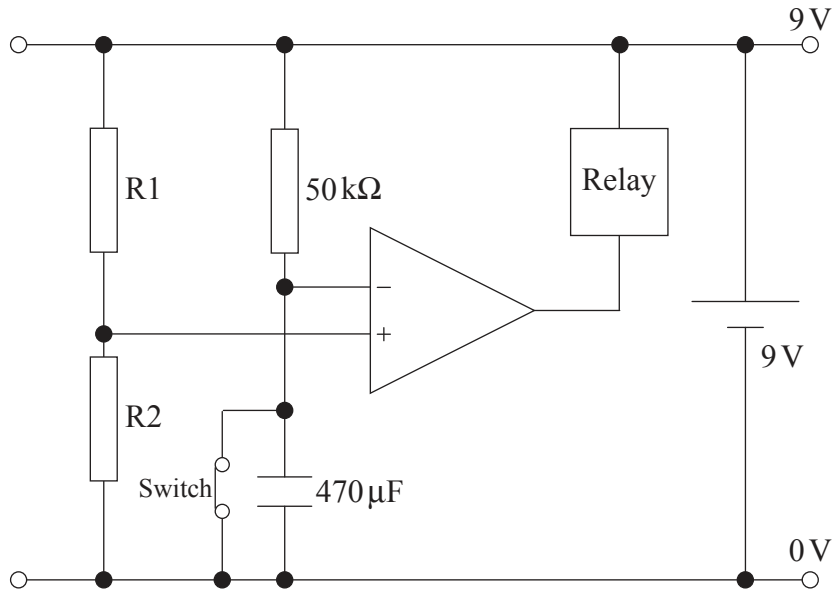

(a) State the type of circuit shown in **Figure B1**. [1]

.....

(b) Calculate the time constant for the circuit. [2]

.....
.....
.....
.....

(This question continues on the following page)



(Question B1 continued)

(c) Explain how the circuit operates when the switch is opened.

[3]

.....

.....

.....

.....

.....

.....



B2. (a) State **one** service cost consideration for the consumer when purchasing a washing machine.

[1]

.....
.....
.....

(b) Outline **one** way in which design for disassembly can promote the upgradeability of electronic products.

[2]

.....
.....
.....
.....



B3. Figure B2 shows two NAND gates.

Figure B2: Two NAND gates

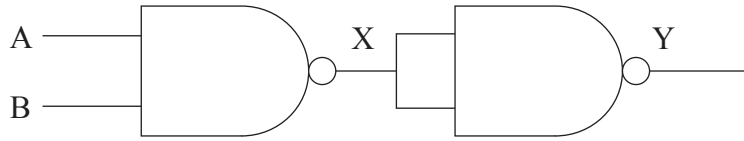

(a) Complete the truth table to show the outputs at X and Y.

[2]

A	B	X	Y
0	0		
0	1		
1	0		
1	1		

(b) Outline **one** reason why, in practice, digital logic functions would be implemented using NAND gates.

[2]

.....

.....

.....

.....



B4. Compare bandwidth implications of time division multiplexing (TDM) with frequency division multiplexing (FDM) for the consumer.

[6]

.....

.....

.....

.....

.....

.....

.....

.....

.....

.....

.....

.....

.....

.....

.....



B5. (a) Describe **one** way in which converging technology could benefit national security. [2]

.....
.....
.....
.....

(b) Outline how nanotechnology could be utilized in the implementation of “The Communicator”. [2]

.....
.....
.....
.....

(c) Describe **one** way in which “The Communicator” promotes global cooperation. [2]

.....
.....
.....
.....



B6. (a) Explain how solar panels could be used in a smart home to generate electrical energy. [3]

.....

.....

.....

.....

.....

.....

(b) Discuss the benefit of using programmable interface controllers (PICs) in a smart home to store data. [3]

.....

.....

.....

.....

.....

.....



Option C — CAD/CAM

C1. **Figure C1** shows a 3D CAD image of a screw fitting made from a plastic, which has been input into a CNC machine.

Figure C1: CAD image of a plastic screw fitting

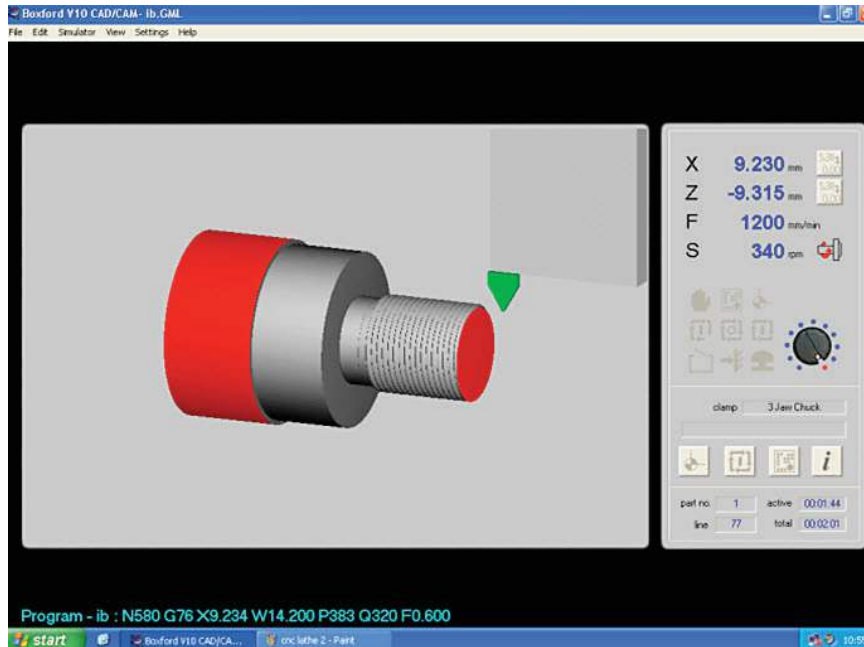

[Source: With the permission of Boxford.]

(a) State the type of the CNC machine used to manufacture the component in **Figure C1**. [1]

.....

.....

(b) Describe how a CNC machine would need to be reprogrammed if the component in **Figure C1** were made from metal instead of plastic. [2]

.....

.....

.....

.....

(This question continues on the following page)



1840

(Question C1 continued)

- (c) Explain why the component in **Figure C1** would require more than one tool for manufacture. [3]

.....

.....

.....

.....

.....

.....



C2. (a) State **one** way in which the use of robots in a manufacturing system has helped to reduce material waste.

[1]

.....
.....

(b) Outline how the use of robots allows for flexibility in a manufacturing system in relation to scale of production.

[2]

.....
.....
.....
.....



C3. **Figure C2** shows a mould flow simulation for injection moulding the plastic casing of an electronic product.

Figure C2: Mould flow simulation for injection moulding the plastic casing of an electronic product

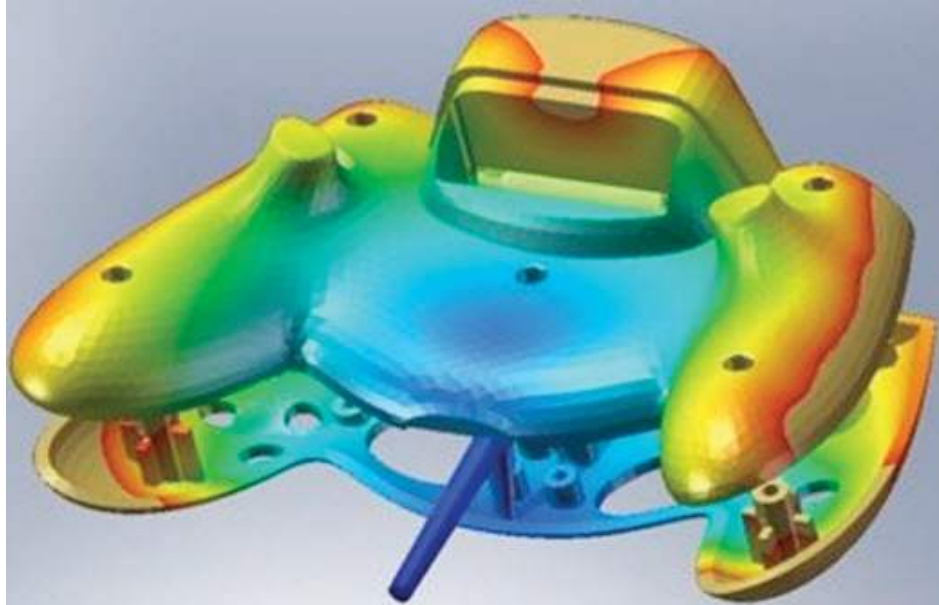

[Source: <http://www.simpoe.com>. Used with permission.]

(a) Describe the purpose of the CAD mould flow simulation. [2]

.....

.....

.....

.....

(b) Outline **one** way in which CAD simulations can aid cost analysis in planning the manufacture of the plastic product. [2]

.....

.....

.....

.....



C4. **Figure C3** shows a prototype design of a perfume bottle with its outer box.

Figure C3: Perfume bottle prototype and outer box



[Source: Designer: Erin Dameron, Brooklyn, New York]

Discuss **two** benefits of using rapid prototyping in the design development of the perfume prototype shown in **Figure C3**.

[6]

.....

.....

.....

.....

.....

.....

.....

.....

.....

.....

.....



C5. (a) Outline **one** disadvantage of CAD for the designer. [2]

.....
.....
.....
.....

(b) Outline **one** way in which CAM has impacted on the role of the manufacturer in a small-scale furniture business. [2]

.....
.....
.....
.....

(c) Outline **one** advantage of exploded view CAD drawings for consumers when deciding whether to purchase flat-pack furniture. [2]

.....
.....
.....
.....



Turn over

C6. **Figure C4** shows a Morgan motor car. **Figure C5** shows a stage in the assembly of Morgan motor cars which are produced using traditional manufacturing methods. The company produces about 675 cars per year to order. Customers have to wait between one and two years before they receive their car.

Figure C4: A Morgan motor car



[Source: <http://www.morgan-motor.co.uk/mmc/hiresimages.html#!prettyPhoto>. Used with permission.]

Figure C5: A stage in the assembly of a Morgan motor car



[Source: <http://rides.webshots.com/photo/22216985100988377631WoqYr>. Used with permission.]

- (a) Suggest **one** reason why the Morgan Motor Company continues to use traditional methods to make the car rather than use CAM. [3]

.....
.....
.....
.....
.....
.....

- (b) Explain **one** social implication of maintaining traditional manufacturing techniques in the Morgan Motor Company. [3]

.....
.....
.....
.....
.....
.....



C7. Discuss **three** benefits for consumers of purchasing classroom furniture produced by CAD/CAM. [9]

A large rectangular box with a dotted line pattern, intended for writing the answer to the question.



Option D — Textiles

D1. Figure D1 shows a woven polyester graft. It is often used in abdominal surgery.

Figure D1: A woven polyester graft

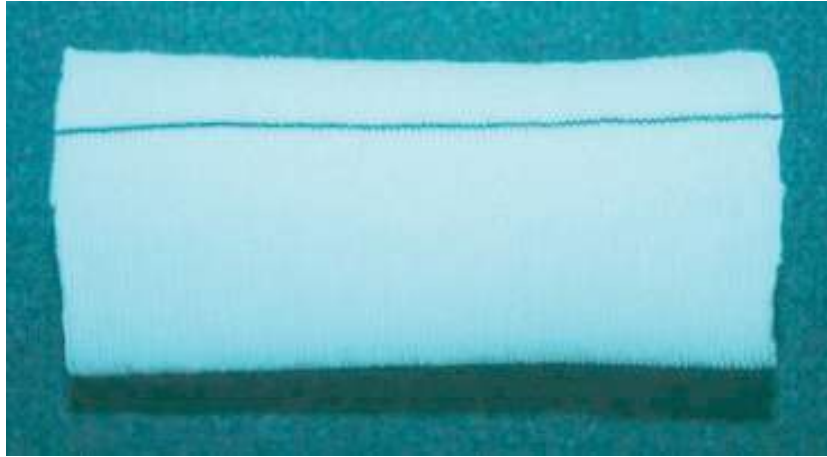

[Source: www.surgical-tutor.org.uk. Used with permission.]

(a) State **one** characteristic of polyester that makes it suitable for the graft apart from biocompatibility. [1]

.....

.....

(b) Outline **one** benefit of using a woven fabric for the graft. [2]

.....

.....

.....

.....

(This question continues on the following page)



(Question D1 continued)

- (c) Explain **one** reason why biocompatibility is important in the development of textile vascular grafts. [3]

.....

.....

.....

.....

.....

.....



D2. (a) State **one** disadvantage of wearable computing for consumers.

[1]

.....
.....
.....
.....

(b) Outline **one** benefit of aligning wearable computing with the fashion market.

[2]

.....
.....
.....
.....



D3. The first industrial knitting machines were designed to create flat knitted items (**Figure D2**). Later knitting machines were developed that would create circular knitted items (**Figure D3**).

Figure D2: An industrial knitting machine for producing flat knitted items



[Source: http://en.wikipedia.org/wiki/File:Stocking_Frame.jpg]

Figure D3: An industrial knitting machine for producing circular knitted items



[Source: http://commons.wikimedia.org/wiki/File:Circular_knitting_machine.jpg]

(a) Outline **one** benefit of the introduction of circular knitting machines for manufacturers. [2]

.....
.....
.....
.....

(b) Outline **one** benefit of circular knitting machines for consumers. [2]

.....
.....
.....
.....



D4. Discuss **two** issues relating to the branding of textile products for adolescents.

[6]

.....

.....

.....

.....

.....

.....

.....

.....

.....

.....

.....

.....

.....

.....

.....



D5. (a) Outline the importance of salt (sodium chloride) in the process of dyeing cotton. [2]

.....
.....
.....
.....

(b) Outline **one** environmental issue involved in the commercial dyeing of cotton products. [2]

.....
.....
.....
.....

(c) Retayne is used on cotton fabrics to fix the dye during the dyeing process. Outline **one** benefit that this will have for the consumer. [2]

.....
.....
.....
.....



D6. (a) Discuss **one** issue relating to the adoption of fair trade regulations for a company in a **developed** country.

[3]

.....
.....
.....
.....
.....
.....

(b) Discuss **one** issue relating to the adoption of fair trade regulations for a company in a **developing** country.

[3]

.....
.....
.....
.....
.....
.....



Option E — Human factors design

E1. Figure E1 shows a seven-point comfort rating scale.

Figure E1: Seven-point comfort rating scale

- 1 perfectly comfortable
- 2 quite comfortable
- 3 not very comfortable
- 4 uncomfortable
- 5 quite uncomfortable
- 6 very uncomfortable
- 7 extremely uncomfortable

(a) State the type of data scale represented by the comfort rating scale in **Figure E1**. [1]

.....

.....

(b) Outline **one** reason for using this type of data scale shown in **Figure E1**. [2]

.....

.....

.....

(c) Explain which point on the comfort rating scale would be appropriate for the design of public seating in a railway station as part of a policy of *Design for Discomfort*. [3]

.....

.....

.....

.....

.....

.....



E2. (a) Define *work-space envelope*.

[1]

.....
.....

(b) Identify **one** piece of anthropometric data required when considering the work-space envelope of a wheelchair user at a desk.

[2]

.....
.....
.....



E3. **Figure E2** shows a door handle. **Figure E3** shows a door knob. Both products are manufactured from polished metal.

Figure E2: Door handle



Figure E3: Door knob



[Source: www.royallensupplies.co.uk]

(a) Outline **one** advantage of the door handle in relation to human factors. [2]

.....
.....
.....

(b) Outline **one** advantage of the door knob in relation to human factors. [2]

.....
.....
.....



E4. **Figure E4** shows The Butterfly Stool designed by Sori Yanagi. The stool is manufactured from moulded plywood with brass fittings.

Figure E4: The Butterfly Stool

[Source: Please go to the link: <http://www.design-museum.de/de/sammlung/100-masterpieces/detailseiten/butterfly-yanagi.html>.]

Discuss **two** human factor considerations in the design of The Butterfly Stool in **Figure E4**. [6]

.....

.....

.....

.....

.....

.....

.....

.....

.....

.....

.....

.....



E5. (a) Outline **one** reason why the background colour of road signs often corresponds to colours used on maps. [2]

.....
.....
.....

(b) Outline **one** advantage of the use of LED signs for authorities responsible for motorways (highways). [2]

.....
.....
.....

(c) Outline **one** disadvantage of the use of LED signs on motorways (highways) for motorists. [2]

.....
.....
.....



E6. (a) Explain **one** reason why human factors research is often not considered a priority in developing countries. [3]

.....

.....

.....

.....

.....

.....

(b) Explain how mass customization has improved the scope for designing for people with disability. [3]

.....

.....

.....

.....

.....

.....



